

SXCIB

Broaching Holders

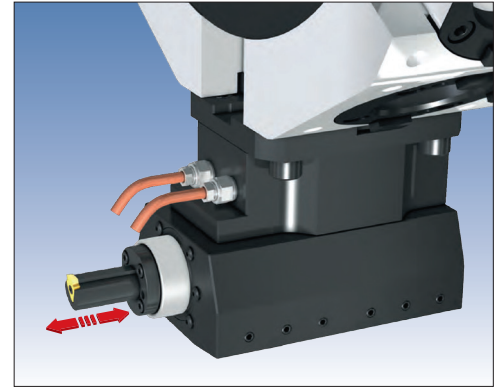

| | | Dimensions | | | |
|---------|---------------------|------------|----|------|------|
| EDP | Designation | WF | LH | OAL | DF |
| 3335386 | SXCIB WTO016-22-50* | 12 | 50 | 61.5 | 38.9 |

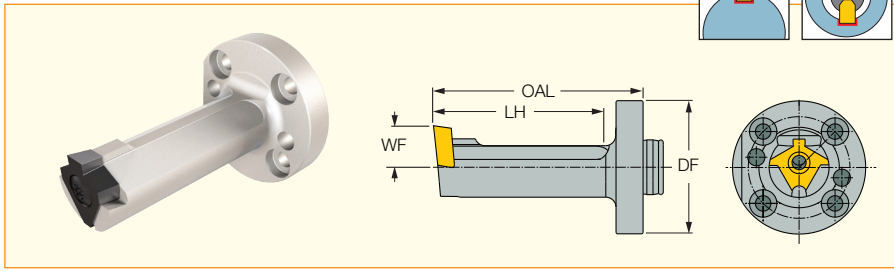
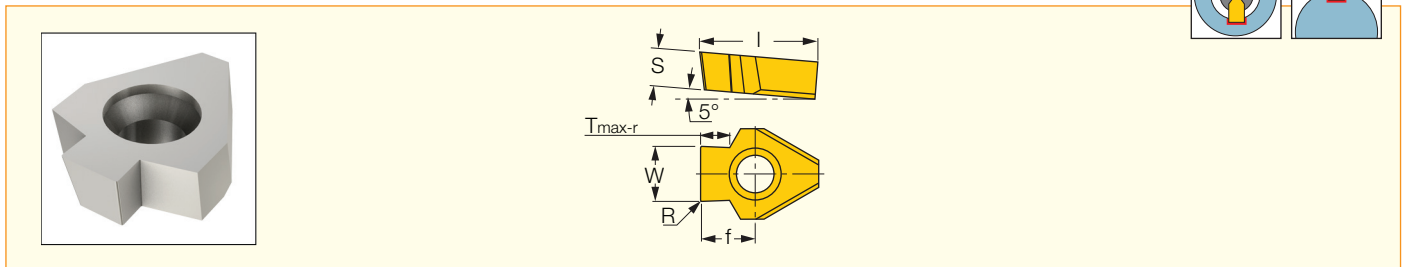

Typical conditions: $V_c = 4000-8000$ mm/min, $a_p = 0.02-0.08$ mm

XNUWB

Inserts for Keyway Broaching, According to DIN138 (Tolerance C11)

| | | Dimensions | | | | | | | IC908 |
|---------|---------------------|----------------|----------------|------|-------|-------------|------|---|-------|
| EDP | Designation | $W_{\pm 0.02}$ | $R_{\pm 0.05}$ | f | l | T_{max-r} | S | | |
| 6405297 | XNUWB 13-6.12-0.85 | 6.12 | 0.85 | 8.0 | 17.30 | 2.60 | 5.30 | ● | |
| 6405298 | XNUWB 13-7.13-0.85 | 7.13 | 0.85 | 8.0 | 17.30 | 3.30 | 5.30 | ● | |
| 6405299 | XNUWB 13-8.13-1.05 | 8.13 | 1.05 | 8.0 | 17.30 | 3.40 | 5.30 | ● | |
| 6405300 | XNUWB 13-10.13-1.05 | 10.13 | 1.05 | 10.9 | 20.20 | 4.20 | 5.30 | ● | |
| 6405301 | XNUWB 13-12.15-1.35 | 12.15 | 1.35 | 10.9 | 20.20 | 5.10 | 5.30 | ● | |
| 6405302 | XNUWB 13-12.15-1.75 | 12.15 | 1.75 | 10.9 | 20.20 | 6.60 | 5.30 | ● | |
| 6405303 | XNUWB 13-12.15-2.25 | 12.15 | 2.25 | 10.9 | 20.20 | 8.50 | 5.30 | ● | |

XNUWB

Inserts for Keyway Broaching, Light Fit (JS9), According to DIN6885

| | | Dimensions | | | | | | | IC908 |
|---------|--------------------|------------|------|-------------|------|-------|-------------|------|-------|
| EDP | Designation | $W^{(1)}$ | R | R^{toler} | f | l | T_{max-r} | S | |
| 6405304 | XNUWB 13-5.01-0.2 | 5.01 | 0.20 | 0.030 | 8.0 | 17.30 | 2.70 | 5.30 | ● |
| 6405305 | XNUWB 13-6.01-0.2 | 6.01 | 0.20 | 0.030 | 8.0 | 17.30 | 3.40 | 5.30 | ● |
| 6405306 | XNUWB 13-8.01-0.2 | 8.01 | 0.20 | 0.030 | 8.0 | 17.30 | 4.10 | 5.30 | ● |
| 6405307 | XNUWB 13-10.01-0.3 | 10.01 | 0.30 | 0.030 | 8.0 | 17.30 | 4.20 | 5.30 | ● |
| 6405308 | XNUWB 13-12.02-0.3 | 12.02 | 0.30 | 0.030 | 10.9 | 20.20 | 5.70 | 5.30 | ● |
| 6405309 | XNUWB 13-12.02-0.5 | 12.02 | 0.50 | 0.050 | 10.9 | 20.20 | 8.50 | 5.30 | ● |

XNUWB

Inserts for Keyway Broaching, Tight Fit (P9), According to DIN6885

| | | Dimensions | | | | | | | IC908 |
|---------|--------------------|------------|----------------|------|-------|-------------|------|---|-------|
| EDP | Designation | $W^{(1)}$ | $R_{\pm 0.03}$ | f | l | T_{max-r} | S | | |
| 6405310 | XNUWB 13-4.98-0.2 | 4.98 | 0.20 | 8.0 | 17.30 | 2.70 | 5.30 | ● | |
| 6405311 | XNUWB 13-5.98-0.2 | 5.98 | 0.20 | 8.0 | 17.30 | 3.40 | 5.30 | ● | |
| 6405312 | XNUWB 13-7.98-0.2 | 7.98 | 0.20 | 8.0 | 17.30 | 4.10 | 5.30 | ● | |
| 6405313 | XNUWB 13-9.98-0.3 | 9.98 | 0.30 | 8.0 | 17.30 | 4.20 | 5.30 | ● | |
| 6405314 | XNUWB 13-11.98-0.3 | 11.98 | 0.30 | 10.9 | 20.20 | 5.70 | 5.30 | ● | |

BDHN

Broaching Holders

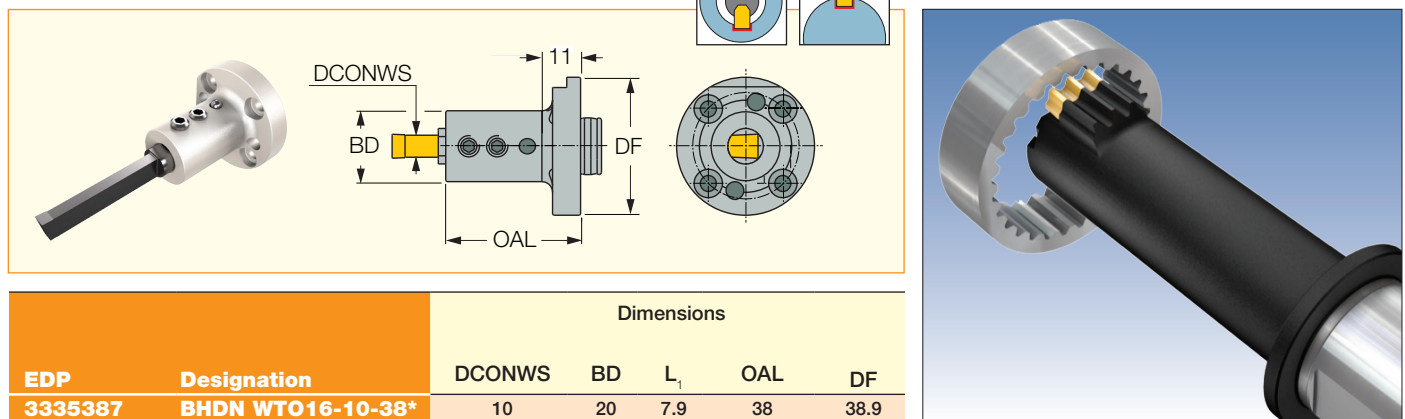

| | | Dimensions | | | | |
|---------|-------------------|------------|----|----------------|-----|------|
| EDP | Designation | DCONWS | BD | L ₁ | OAL | DF |
| 3335387 | BHDN WTO16-10-38* | 10 | 20 | 7.9 | 38 | 38.9 |

Special Tooling Available Upon Request

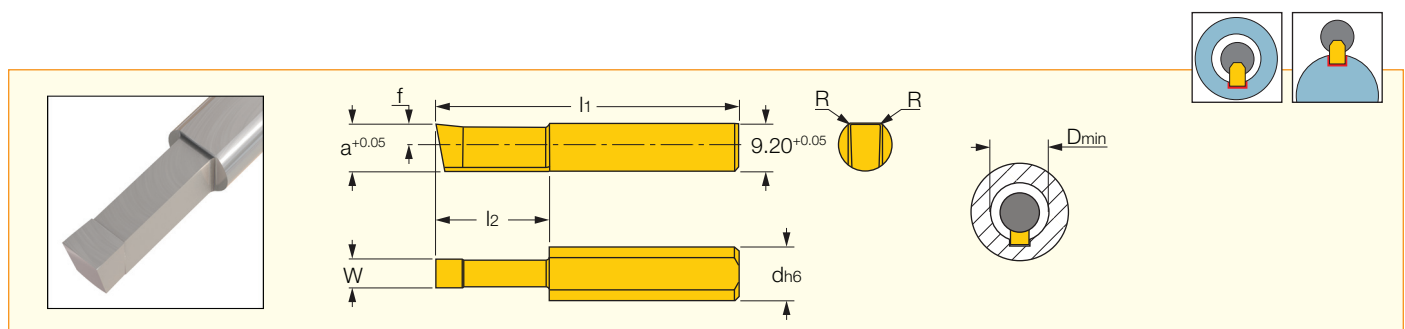

Typical conditions: Vc = 4000-8000 mm/min, ap = 0.02 - 0.08 mm

SCB

Inserts for Keyway Broaching, According to DIN138 (Tolerance C11)

| | | Dimensions | | | | | | | | IC908 |
|---------|--------------------|--------------------|--------------------|-------|-----|------|----------------|----------------|------------------|-------|
| EDP | Designation | W ^{±0.02} | R ^{±0.05} | d | f | a | l ₁ | l ₂ | D _{min} | |
| 6405315 | SCB 010.410.050-25 | 4.10 | 0.50 | 10.00 | 4.0 | 9.00 | 50.00 | 25.0 | 10.00 | ● |
| 6405316 | SCB 010.410.050-41 | 4.10 | 0.50 | 10.00 | 4.0 | 9.00 | 66.00 | 41.0 | 10.00 | ● |
| 6405317 | SCB 010.510.050-25 | 5.10 | 0.50 | 10.00 | 4.0 | 9.00 | 50.00 | 25.0 | 10.00 | ● |
| 6405318 | SCB 010.510.050-41 | 5.10 | 0.50 | 10.00 | 4.0 | 9.00 | 66.00 | 41.0 | 10.00 | ● |

SCB

Inserts for Keyway Broaching, Light Fit (JS9), According to DIN6885

| | | Dimensions | | | | | | | | IC908 |
|---------|--------------------|---------------------|--------------------|-------|-----|------|----------------|----------------|------------------|-------|
| EDP | Designation | W ^{±0.015} | R ^{±0.03} | d | f | a | l ₁ | l ₂ | D _{min} | |
| 6405319 | SCB 010.400.020-25 | 4.00 | 0.20 | 10.00 | 4.0 | 9.00 | 50.00 | 25.0 | 10.00 | ● |
| 6405320 | SCB 010.400.020-41 | 4.00 | 0.20 | 10.00 | 4.0 | 9.00 | 66.00 | 41.0 | 10.00 | ● |
| 6405321 | SCB 010.500.020-25 | 5.00 | 0.20 | 10.00 | 4.0 | 9.00 | 50.00 | 25.0 | 10.00 | ● |
| 6405322 | SCB 010.500.020-41 | 5.00 | 0.20 | 10.00 | 4.0 | 9.00 | 66.00 | 41.0 | 10.00 | ● |

SCB

Inserts for Keyway Broaching, Tight Fit (P9), According to DIN6885

| | | Dimensions | | | | | | | | IC908 |
|---------|--------------------|------------------|--------------------|-------|-----|------|----------------|----------------|------------------|-------|
| EDP | Designation | W ⁽¹⁾ | R ^{±0.03} | d | f | a | l ₁ | l ₂ | D _{min} | |
| 6405323 | SCB 010.398.020-25 | 3.98 | 0.20 | 10.00 | 4.0 | 9.00 | 50.00 | 25.0 | 10.00 | ● |
| 6405324 | SCB 010.398.020-41 | 3.98 | 0.20 | 10.00 | 4.0 | 9.00 | 66.00 | 41.0 | 10.00 | ● |
| 6405325 | SCB 010.498.020-25 | 4.98 | 0.20 | 10.00 | 4.0 | 9.00 | 50.00 | 25.0 | 10.00 | ● |
| 6405326 | SCB 010.498.020-41 | 4.98 | 0.20 | 10.00 | 4.0 | 9.00 | 66.00 | 41.0 | 10.00 | ● |